

Last updated 29/11/2021



Committee Structure, Membership and Representation

2019 - 2022 Triennium

Adopted 24 November 2021

Doc ID A1489783

Otago Regional Council Committee Memberships	3
Terms of Reference 2019-2022	4
Finance Committee.....	4
Strategy and Planning Committee	6
Regulatory Committee.....	8
Data and Information Committee	9
Implementation Committee.....	10
Governance, Communications and Engagement Committee	11
Chief Executive Performance Review Committee.....	12
Audit and Risk Subcommittee	13
Otago Civil Defence Emergency Management Group (Joint Committee).....	15
Otago Regional Transport Committee	18
Council Established Working Groups	21
ECO Fund Decision Panel Chair	21
Port Otago Liaison Working Group	21
Catchment Catchment Community Governance Group	21
COVID-19 Recovery/Jobs for Nature Working Group	21
Appointments as Representatives of Council.....	22
<i>Mana to Mana.....</i>	22
<i>Local Government New Zealand Regional Sector Group and Zone 6 Group.....</i>	22
<i>Otago Mayoral Forum / CDEM Joint Committee</i>	22
<i>Manuherehia Reference Group</i>	22
<i>Connecting Dunedin</i>	22
<i>Way to Go.....</i>	22
<i>Lower Waitaki River Scheme Liaison</i>	22
Freshwater Management Unit (FMU) and rohe Liaisons.....	23
Freshwater Management Unit (FMU) Map.....	24

Otago Regional Council Committee Memberships

Finance Committee	Strategy and Planning Committee	Data and Information Committee
Cr Hilary Calvert: Co-Chair Cr Kevin Malcolm: Co-Chair All Councillors	Cr Gretchen Robertson: Co-Chair Cr Kate Wilson: Co-Chair All Councillors Iwi representatives: Mr Edward Ellison Dr Lyn Carter	Cr Alexa Forbes: Co-Chair Cr Michael Laws: Co-Chair All Councillors

Regulatory Committee	Implementation Committee	Governance, Communications and Engagement Committee
Cr Gary Kelliher: Co-Chair Cr Andrew Noone: Co-Chair All Councillors	Cr Bryan Scott: Co-Chair Cr Carmen Hope: Co-Chair All Councillors	Cr Michael Laws: Co-Chair Cr Michael Deaker: Co-Chair All Councillors

Audit and Risk Subcommittee (of Finance Committee)	Chief Executive Performance Review Committee
Cr Hilary Calvert (Chair) Cr Kevin Malcolm Cr Andrew Noone Cr Kate Wilson Mr Andrew Douglas	Cr Andrew Noone (Chair) Cr Hilary Calvert Cr Michael Deaker Cr Alexa Forbes

Regional Transport Committee	Otago Civil Defence and Emergency Management Group Joint Committee
Cr Alexa Forbes (Chair) Cr Kate Wilson (Deputy Chair) Cr Jim O'Malley (DCC) Cr Bruce Graham (CDC) Cr Stuart Duncan (CODC) Cr Quentin Smith (QLDC) Cr Guy Percival (WDC) Jim Harland (NZTA) Alternates: Cr David Benson-Pope (DCC) Graeme Hall (NZTA) Cr Bill Kingam (WDC) Cr Michael Deaker (ORC)	Cr Andrew Noone (Deputy Chair) Otago Region Mayors

Terms of Reference 2019-2022

Finance Committee

Purpose

To guide and monitor the Council's financial, commercial and administrative affairs, including the Port shareholding and operational performance, Long Term Plan, Annual Plans and implementation of the Local Government Act 2002.

Reporting

The Finance Committee reports to Council.

Membership

Co-Chair – Cr Hilary Calvert

Co-Chair – Cr Kevin Malcolm

The Finance Committee shall have a membership of all elected Councillors.

A quorum of the Finance Committee shall be six members.

The Chief Executive and General Manager Corporate Services are to attend meetings.

Meetings

The Finance Committee will have ordinary meetings at quarterly intervals and will otherwise meet as required. When preparing business items for an agenda the General Manager Corporate Services should consult the Co-Chairs.

Key Responsibilities

The Finance Committee has the following key responsibilities:

- Monitor and review Council's operational performance against the agreed levels of service and target measures outlined in the Long-Term and Annual Plans
- Review quarterly and annual financial statements including the statement of comprehensive income, balance sheet and treasury report
- Oversee the Long Term and Annual Plan process including consultation and hearings and make recommendations to Council for adoption
- Oversee all financial policies including the Financial Strategy and Revenue and Financing Policy
- Review and make recommendation on rates, fees, charges, royalties and rentals
- Review the Statement of Corporate Intent and receive the six month and annual reports of Port Otago Limited
- Review and make recommendations concerning any commercial activities, trading activities or investments held by the Council
- Maintain an overview of Councils assets, leases and financial reserves
- Maintain oversight of Council's financial risk and management of that risk
- Endorse submission in relation to the Local Government Act 2002.

Delegations

The Finance and Committee shall have the following delegations:

- To award or approve contracts and tenders in excess of staff delegations and to a maximum of \$2million.

- To approve the Draft Annual Plan-and Draft Long-Term Plan and associated policies, and to conduct all consultation and hearings with the public concerning them.
- To consider matters of financial impact other than as provided for in the Annual Plan.
- To endorse submissions in relation to the Local Government Act 2002.
- The Finance Committee shall carry out any other function or duty delegated to it by the Council.
- The Finance Committee may appoint subcommittees or working parties as appropriate provided they are limited to a time duration consistent with performance of their specified tasks.

Way of working

Issues for decision, and information for noting will generally be presented in papers.

Strategy and Planning Committee

Purpose

Assist the Council set the organisation's mission, vision and strategic direction (the 'strategic plan'). Monitor performance against the strategic plan. Develop and recommend to Council strategies, policies and plans that enable the ORC to deliver on its strategic plan and its legislative requirements. Assess the effectiveness of strategies, policies and plans.

Reporting

The Strategy & Planning Committee reports to the Council.

Membership

Co-Chair - Cr Gretchen Robertson

Co-Chair - Cr Kate Wilson

The Strategy & Planning Committee shall have a membership of all elected Councillors plus two Iwi representatives with full voting rights.

A quorum of the Strategy & Planning Committee shall be eight members.

Meetings

The Strategy & Planning Committee will have:

- Meetings twice a quarter;
- Three to five half day workshops per annum; and
- Other meetings or workshops as required.

When preparing business items for an agenda the General Manager Strategy, Policy and Science should consult the Co-Chairs.

Key Responsibilities

The Strategy & Planning Committee will:

- Periodically review and make recommendations to Council in relation to ORC's mission, vision, strategic initiatives, major programmes and services
- Review the strategic plan and recommend updates as needed based on changes in the ORC's external operating environment
- Monitor and report on the organisation's performance against its strategic plan
- Identify critical strategic issues facing the organisation and make recommendations on options to address these
- Provide policy guidance and direction in respect of the preparation or amendment of **any** strategies, policies and plans over which it has oversight (*list includes, but is not limited to, Resource Management Act Plans, the Regional Passenger Transport Plan, the Pest Plan etc*)
- Have oversight of ORC's programme of work on **climate change**, including adaptation and mitigation and provide guidance on programme direction
- Periodically review and make recommendations to Council in relation to strategies, policies and plans for specific ORC's functions particularly those that arise from legislative requirements
- Make submissions to other authorities and government
- Monitor and report on the effectiveness of ORC's strategies, policies and plans
- Maintain oversight of risks associated with strategy and planning functions
- Receive updates of progress on the above.

Delegations

- The Strategy & Planning Committee has delegations from the Council to make submissions and representations on matters within its statement of purpose on Otago councils' district plans and neighbouring councils' regional plans to ensure consistency.
- The Strategy & Planning Committee may, where consistent with all relevant statutes, approve public consultation and call for submissions on this Council's draft, proposed, and indicative policies, plans and strategies. This delegation does not include formal notification of Council's proposed plans.
- The Strategy & Planning Committee may endorse submissions or appeals concerning district planning and consents within Otago; submissions on legislation and regulations (including submissions to Parliamentary Select Committees), and submissions on crown agency and parliamentary discussion documents.
- The Strategy and Planning Committee shall carry out any other function or duty delegated to it by the Council.
- The Strategy and Planning Committee may appoint subcommittees or working parties as appropriate provided they are limited to a time duration consistent with performance of their specified tasks.

Way of working

Issues for decision, and information for noting will generally be presented in papers. Presentations will also be used. Workshops will be used to provide input in development of policies, plans and strategies.

Regulatory Committee

Purpose

To oversee Council's consenting and compliance functions under the Resource Management Act, Biosecurity Act and Building Act, as well as any functions carried out by the Harbourmaster.

Reporting

The Regulatory Committee reports to the Council.

Membership

Co-Chair – Cr Gary Kelliher

Co-Chair - Cr Andrew Noone

The Regulatory Committee shall have a membership of all elected Councillors.

A quorum of the Regulatory Committee shall be six members.

Meetings

The Regulatory Committee will have ordinary meetings at quarterly intervals and will otherwise meet as required. When preparing business items for an agenda the General Manager Regulatory should consult the Co-Chairs.

Key Responsibilities

The Regulatory Committee shall take an overview of and report on:

- Consents processes, including RMA, Building Act and Bylaws
- The monitoring of compliance with council issued consents, and any follow up actions or enforcement action required
- The monitoring of compliance with council's plans, and any follow up actions or enforcement action required
- The effectiveness of council plans in meeting Council objectives and associated recommendations to Council
- Changes in council's external operating environment which will affect the delivery of consenting and compliance functions
- The delivery of the Harbourmaster functions and associated Navigational Safety Bylaw;
- The monitoring of compliance and enforcement activity under **any** Act and any follow up actions required
- Risks associated with council delivering its consenting and compliance functions, and harbourmaster functions.

Delegations

- The Regulatory Committee may recommend to Council the approval of functional strategies, project concepts and implementation plans.
- The Regulatory Committee may appoint subcommittees or working parties as appropriate provided they are limited to a time duration consistent with performance of their specified tasks.
- The Regulatory Committee shall carry out any other function or duty delegated to it by the Council.

Way of working

Issues for decision, and information for noting will generally be presented in papers.

Data and Information Committee

Purpose: To receive data, information and analysis on environmental, economic, cultural and social matters pertaining to ORC's functions. Refer issues to other committees, if required.

Reporting

The Data and Information Committee reports to Council

Membership

Cr Alexa Forbes - Co-Chair

Cr Michael Laws – Co-Chair

The Data and Information Committee shall have a membership of all elected Councillors.

A quorum of the Data and Information Committee shall be six members.

Meetings

The Data and Information Committee will have ordinary meetings at quarterly intervals and will otherwise meet as required. When preparing business items for an agenda the General Manager Strategy, Policy and Science should consult the Co-Chairs.

Key responsibilities

- Oversight of the environmental monitoring programme to ensure it supports ORC's strategies, policies and plans
- Oversight of the development and implementation of the environmental monitoring network
- Oversight of the data governance and systems
- Oversight of the development of analysis that informs the development of ORC's strategies, policies and plans
- Oversight of the development of evidence that informs the development of ORC's strategies, policies and plans
- Review of State of the Environment monitoring, analysis and reporting
- Receive data, information and analysis on Otago's natural and built environment
- Receive economic data, information and analysis
- Receive social and cultural data, information and analysis
- Receive information, data and science on natural hazards and **climate change**
- Identification of natural hazard risks in Otago and key future drivers in managing them (e.g., land use change and **climate change**).

Delegations

- Receive information, presentations, and reports.
- Can refer issues to other committees for further discussion.

Way of Working

Information presented to the Committee will be a mix of presentations, papers, and guest speakers.

Implementation Committee

Purpose

To monitor and oversee what the ORC delivers, and how we deliver against existing strategies and plans, alongside our non-regulatory programme of work.

Reporting

The Implementation Committee reports to Council.

Membership

Cr Bryan Scott - Co-Chair

Cr Carmen Hope - Co-Chair

The Implementation Committee shall have a membership of all elected Councillors.

A quorum of the Implementation Committee shall be six members.

Meetings

The Implementation Committee will have ordinary meetings at quarterly intervals and will otherwise meet as required. When preparing business items for an agenda the General Manager Operations should consult the Co-Chairs.

Key Responsibilities

The Implementation Committee will receive updates on, and have oversight on the following matters:

- All non-regulatory implementation activities, including (but not limited to):
 - ORC work with catchment groups
 - Biodiversity strategy implementation
 - Biosecurity strategy/operational plan implementation (rabbits, etc)
 - Air Strategy implementation
- Provision of transport services
- The development and delivery of programmes for managing natural hazards risks
- The establishment and review of levels of service for waterway management, flood control and land drainage
- Monitoring the condition and performance of council's river management, flood control and land drainage schemes
- Assisting in developing programmes for improving the condition and performance of council's river management, flood control and land drainage schemes and reducing service delivery risks
- Monitoring the effectiveness and reliability of natural hazards monitoring and warning systems and processes
- The ECO Fund

Delegations

- The Implementation Committee may appoint subcommittees or working parties as appropriate provided they are limited to a time duration consistent with performance of their specified tasks.
- The Implementation Committee shall carry out any other function or duty delegated to it by the Council.

Way of Working

Information presented to the Committee will be a mix of presentations, staff report backs and some papers.

Governance, Communications and Engagement Committee

Purpose

To monitor and oversee governance, communications and engagement at the Council.

Reporting

The Governance, Communications and Engagement Committee reports to Council.

Membership

Cr Michael Laws: Co- Chair

Cr Michael Deaker: Co-Chair

The Governance, Communications and Engagement shall have a membership of all elected Councillors.

A quorum of the Governance, Communications and Engagement Committee shall be six members.

Meetings

The Governance, Communications and Engagement Committee will have ordinary meetings at quarterly intervals and will otherwise meet as required. When preparing business items for an agenda the Executive Advisor should consult the Co-Chairs.

Key Responsibilities

The Governance, Communications and Engagement Committee will:

- Overview and provide strategic support to the Council's public and stakeholder engagement
- Community engagement on natural hazards risks and council's river management programme, flood control and land drainage schemes
- Support elected members in their roles
- Overview Rural Liaison/Urban Liaison/Youth engagement activities
- Consider any governance matters, including Standing Orders, Code of Conduct, Remuneration and Allowance, Committee Structure

Delegations

- The Governance, Communications and Engagement Committee may appoint subcommittees or working parties as appropriate provided they are limited to a time duration consistent with performance of their specified tasks.
- The Governance, Communications and Engagement Committee shall carry out any other function or duty delegated to it by the Council.

Way of Working

Information presented to the Committee will be a mix of presentations and papers.

Chief Executive Performance Review Committee

Purpose

To undertake performance assessments, negotiate any matters relating to the Chief Executive's employment contract and agree and review key result areas.

Membership

Cr Andrew Noone (Chair)
Cr Hilary Calvert
Cr Michael Deaker
Cr Alexa Forbes

A quorum of the Chief Executive Performance Review Committee shall be three members.

Meeting frequency

Routinely twice a year, once in December and once in June or at the discretion of the Chair

The Chief Executive Performance Review Committee will report to Council.

Audit and Risk Subcommittee

Purpose

To assist the ORC in fulfilling governance responsibilities relating to its financial, reporting, legislative, health and risk management practices.

Reporting

The Audit and Risk Subcommittee reports to the Finance Committee.

Membership

Cr Hilary Calvert, Chair

Cr Andrew Noone

Cr Kate Wilson

Cr Kevin Malcolm

Mr Andrew Douglas (independent member)

The Subcommittee has the ability to co-opt other Councillors.

Other Councillors are encouraged to attend and participate in meetings of the Subcommittee.

A quorum of the Audit and Risk Subcommittee shall be three members.

Meetings

The Audit and Risk Subcommittee will have ordinary meetings at quarterly intervals and will otherwise meet as required. When preparing business items for an agenda the General Manager Corporate Services should consult the Co-Chairs.

Attendance at Meetings

- The Chief Executive and the General Manager Corporate Services are to attend meetings.
- Other external parties may be invited to attend by the Subcommittee as required.
- There shall be at least one meeting per year where the external Auditors shall attend.

Key Responsibilities

The Audit and Risk Subcommittee has the following key responsibilities:

Audit and Reporting

- Review the external Auditor's audit plan, audit management letter and management response to any issues raised during the external audit.
- Oversee any internal audit functions or reviews and consider any matters referred to it by that function.
- Oversee internal control processes and procedures including financial policies, delegations and sensitive expenditure.
- Consider changes in accounting policies, standards or reporting requirements and make recommendations for Council adoption.
- Review the draft Annual Report including the Statement of Service and Performance and Financial Statements and make recommendation for Council adoption.

Risk Management

- Ensure a corporate risk management framework is in place and review risk reports.
- Review Council's insurance matters and annual renewal process.
- Review Council's business continuity and disaster recovery matters.

Health and Safety

- Review Council's adherence to the Health and Safety at Work Act 2015 including monitoring health and safety performance, incidents and response.

Investments

- Review the performance of Council's investment portfolio including the long-term managed fund.
- Oversee the performance of Council's investment manager including compliance of the managed fund with the Statement of Investment Policies and Objectives (SIPO).
- Review the Treasury Management Policy and SIPO and recommend changes to Council as required.
- Oversee the Investment Manager appointment process and make recommendations to Council on that appointment.

Legal Compliance

- Receive and consider updates on legislation that Council is required to operate under and/or enact.
- Review Council's adherence to legislation that affects Council.

Other

- Review any other financial matters referred to the Subcommittee by Council or the Finance Committee.

Reporting

- The Subcommittee shall conduct an annual review of its work and the Chairperson shall report to Council at the end of each financial year.

Delegations

The Audit and Risk Subcommittee shall have the following delegations:

- Review matters within its terms of reference and make recommendations to Council or the Finance Committee on those matters.
- Seek information it requires from the Chief Executive. The Chief Executive is required to cooperate with any requests unless excused by the Chair of the Otago Regional Council.
- Request access to outside legal or independent professional advice should it consider this necessary.

The Audit and Risk Subcommittee may not delegate any of its responsibilities, duties or powers.

Way of working

Issues for decision, and information for noting will generally be presented in papers. Presentations will also be used.

Otago Civil Defence Emergency Management Group (Joint Committee)

Constitution

Pursuant to section 12 of the Civil Defence Emergency Management Act 2002, the Otago Civil Defence Emergency Management Group is constituted as a joint standing committee under section 114S of the Local Government Act 1974 (a joint committee under section 30 of Schedule 7 of the Local Government Act 2002) by resolutions adopted by:

- Central Otago District Council
- Clutha District Council
- Dunedin City Council
- Otago Regional Council
- Queenstown Lakes District Council
- Waitaki District Council

Membership

Each local authority listed above is a member of the Otago Civil Defence Emergency Management Group. Each member is represented on the joint committee by the Mayor/ Chairperson, or by an elected person from that authority who has delegated authority to act for the member.

Chairperson

The Otago Civil Defence Emergency Management Group shall appoint one of the representatives of its members as chairperson, and one of its members as deputy chairperson. Each will hold office for such period as agreed by the Group, but only so long as those persons remain a representative of a member of the Group.

Purpose

The Otago Civil Defence Emergency Management Group has the purpose and all of the functions, powers and obligations of a civil defence emergency management group as defined by the Civil Defence Emergency Management Act 2002 and subsequent amendments. Section 17 of the Civil Defence Emergency Management Act 2002 defines the function of a group and each of its members that, in summary, require it to:

- Identify, assess and manage relevant hazards and risks;
- Ensure provision of trained and competent personnel, an appropriate organisational structure and the necessary services and resources for effective civil defence emergency management in its area;
- Respond to and manage the adverse effects of emergencies;
- Carry out recovery activities;
- Assist other civil defence emergency management groups when requested;
- Promote public awareness of and compliance with the Civil Defence Emergency Management Act and legislative provisions relevant to the purpose of the Act;
- Develop, approve, implement, monitor and review a civil defence emergency management group plan;
- Participate in the development of the national civil defence emergency management strategy and the national civil defence emergency management plan.
- Promote civil defence emergency management in its area that is consistent with the purpose of the Civil Defence Emergency Management Act 2002.

Meetings

The Otago Civil Defence Emergency Management Group shall meet quarterly and as required with the location for meetings rotating among member authorities.

Quorum

The quorum of the Otago Civil Defence Emergency Management Group shall be three members.

Delegations

The Otago Civil Defence Emergency Management Group shall have all the delegated authorities that may be given by each member Council, including authority to fulfil the powers, obligations and functions of the Group as specified in the Civil Defence Emergency Management Act 2002, authority to appoint subcommittees, and authority to sub-delegate any authority able by law to be delegated.

Subcommittee

A subcommittee of all members of the Otago Civil Defence Emergency Management Group may be formed and given full delegated authority to carry out the functions, obligations and powers of the Group under the Civil Defence Emergency Management Act 2002 pursuant to section 114P(2) of the Local Government Act 1974 and section 30(2) schedule 7 of the Local Government Act 2002. Any meeting will transact routine business and not commit members to any major financial expenditure.

Standing Orders

The current Standing Orders of the Otago Regional Council shall govern the conduct of the meetings, except that order papers and agenda papers shall be sent to every member no less than five working days before the meeting. Notwithstanding anything in the Civil Defence Emergency Management Act or Standing Orders, adequate notice shall be given of all matters to be discussed at a meeting of the Group. Where a matter of significance is to be considered, where practicable, prior written notice of the background to that matter must be given in sufficient time to allow for consultation with each member.

Administering Authority

The Otago Regional Council as the administering authority shall provide administrative and leadership of the Group.

Reporting

The Group will report to each member.

Continuance of Joint Standing Committee

The Otago Civil Defence Emergency Management Group shall not be discharged by a triennial election but appointments of representatives of members shall be confirmed or new appointments made by each council following each election.

Otago CDEM Group Governance Structure

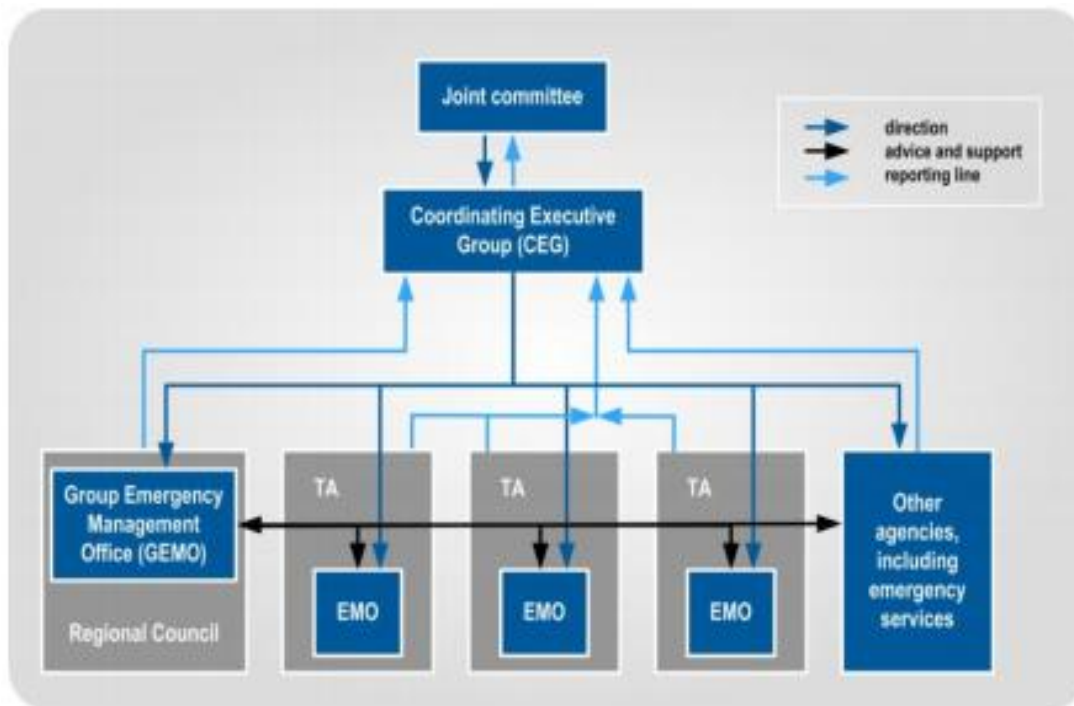

The **Otago CDEM Group Joint Committee**, made up of all the mayors from the five districts and the chairperson of the Regional Council, has overall governance responsibility for CDEM in the Otago area. The Chair is Mayor Aaron Hawkins, Dunedin City Council and the Deputy Chair is Councillor Andrew Noone, Chairperson, Otago Regional Council.

Operational management is supported by the **Coordinating Executive Group (CEG)**, made up of the Chief Executives of the six councils (or persons acting on their behalf), plus senior representatives from the NZ Police, Fire and Emergency NZ, St John, Southern District Health Board, Ngāi Tahu and the Ministry of Social Development. The CEG provides advice to the JC and ensures its decisions are implemented. The Chair is the Chief Executive of the Otago Regional Council.

Otago CDEM Group Management Office is a shared service across all six local authorities of Otago. Otago Regional Council is the Administering Authority for the CDEM Group. It:

- Employs all staff of Otago CDEM Group and is responsible for all employment-related matters including health and safety, wellbeing, welfare, operational policies, and conduct.
- Provides administrative and related services to the Group, such as preparing agendas, arranging meetings, and taking and disseminating minutes from meetings.
- Provides financial management for the CDEM Group, including budgeting and reporting.

In addition to the funding collected by the Regional Council through the targeted rate to resource the Otago CDEM Group and its activities.

Each **local authority member** of the Group is operationally and financially responsible for its **own local arrangements**. Each council also contributes skills, expertise and mutual support to the Group on an 'as available' basis.

For more information please see: <https://www.otagocdem.govt.nz/media/1417/otago-cdem-group-plan-2018-28-print-version.pdf>

Otago Regional Transport Committee

Objective

To undertake the functions as prescribed by the *Land Transport Management Act 2003 and subsequent amendments*.

Membership

The Regional Transport Committee for Otago (RTC) comprises:

- two regional council representatives (Chair and Deputy Chair);
- one representative from the Waka Kotahi NZ Transport Agency;
- one district council representative from each of the:
 - Central Otago District Council
 - Clutha District Council
 - Dunedin City Council
 - Queenstown Lakes District Council
 - Waitaki District Council

Total membership of the Otago committee equals eight. This is dictated by Section 105 of the *Land Transport Management Act 2003 (LTMA)*.

Representatives are appointed by the Regional Council on the nomination of NZ Transport Agency and each of the territorial local authorities.

Members for 2019 – 2022:

Otago Regional Council, Cr Alexa Forbes (Chair)

Otago Regional Council, Cr Kate Wilson

Waka Kotahi NZ Transport Agenda, Mr Jim Harland

Central Otago District Council, Cr Stuart Duncan

Clutha District Council, Cr Bruce Graham

Dunedin City Council, Cr Jim O'Malley

Queenstown Lakes District Council, Cr Quentin Smith

Waitaki District Council, Cr Guy Percival

Meeting Schedule

The RTC normally meets at least three times a year but may meet more regularly depending on the work to be undertaken or the issues to be addressed. Where possible, members will be advised, in advance, of the meeting schedule for the year.

Role and Functions

The role and functions of the Regional Transport Committee are as follows:

1. To undertake the statutory requirements of the *Land Transport Management Act 2003*;
2. To prepare the Regional Land Transport Plan (RLTP) in co-operation with the Otago Regional Transport Committee, to prepare any applications to vary the RLTP and to process any applications to vary the RLTP (*LTMA Section 106(1)(a)*);
3. To prepare and adopt a policy that determines significance in respect of:
 - a) any variations made to the RLTP;
 - b) activities included in the RLTP (*LTMA Section 106(2)*).

4. To provide any advice and assistance the regional council may request on its transport responsibilities generally (*LTMA Section 106(1)(b)*);
5. To undertake monitoring to assess implementation of the Regional Land Transport Plan including monitoring of the performance of activities (*LTMA Section 16(3)(f) and 16(6)(e)*), in co-operation with the Otago Regional Transport Committee;
6. To consult on a draft RLTP for the region in accordance with the consultation principles specified in Section 18 and 18A of the *Land Transport Management Act 2003*, in co-operation with the Otago Regional Transport Committee;
7. To complete a review of the RLTP during the six-month period immediately before the expiry of the third year of the Plan (*LTMA Section 18CA*) in co-operation with the Otago Regional Transport Committee;
8. To advise the Council on any significant legislative changes, programmes, plans or reports relating to the region's transport system;
9. To prepare and implement regional transportation planning studies, or pan-regional studies with the Otago Regional Transport Committee, when necessary;
10. To represent and advocate for transport interests of regional and/or pan-regional Otago Southland concern;
11. To consider and submit on transport-related policies, plans and consultation documents issued by the Ministry of Transport, Waka Kotahi NZ Transport Agency, regional/district councils, and other relevant organisations as considered appropriate, including submitting jointly with the Otago Regional Transport Committee, when appropriate;
12. To liaise with the Ministry of Transport, Waka Kotahi NZ Transport Agency, Commissioner of Police, regional/district councils, KiwiRail, the Department of Conservation and other interested parties on transport matters, and advise the Council on any appropriate new initiatives as considered appropriate;
13. To operate in a collaborate manner in the combined meetings of the Otago and Southland regional transport committees and to engage with other regional transport committees and working parties, which from time-to-time may be established;
14. To consider advice and recommendations from the Otago Southland Regional Technical Advisory Group.

Members' responsibilities for reporting back to the organisation they represent

Each member of the Regional Transport Committee is expected to report back to their own organisations following each Regional Transport Committee meeting or workshop on matters discussed at those Committee meetings, and with particular reference to the RLTP. A briefing paper will be produced by the Regional Council for distribution to stakeholders and to assist members with their report back responsibilities.

Terms of Membership

Should a vacancy occur in the membership of the RTC, the Committee Secretary shall report this to the next meeting of the Council, which shall then invite the nominating organisation to nominate a replacement.

Quorum and Voting Rights

An Otago RTC meeting cannot proceed unless five committee members are present, at least one of whom must be representative of the regional council and no more than one to be an alternate representative.

No voting will occur unless there is a quorum of committee members from those organisations allowed to vote on these matters.

The Chairperson has a deliberative vote and in the case of an equality of votes does not have a casting vote. Clause 24 of the 7th Schedule of the Local Government Act otherwise applies to voting.

The purpose of encouraging each organisation to have alternates is to ensure that each of the organisations involved in the RTC (the TAs, Waka Kotahi NZ Transport Agency and the regional council) is able to bring their organisation's view to the table and to report back the outcome to their organisation.

Each organisation (i.e. the regional council, Waka Kotahi NZ Transport Agency and each district/city council) is therefore encouraged to have alternative representatives to act as a replacement should the appointed representative be absent from a meeting.

Alternates will count towards a quorum but do not have voting rights.

Delegated Authority – Power to Act

The Regional Transport Committee:

1. Does have the ability to appoint a panel to hear RLTP, submissions, working parties, advisory groups and, where there is urgency or special circumstances, a sub-committee to deal with any matters of responsibility within the Committee's Terms of Reference and areas of responsibility, and to make recommendations to the Committee on such matters, provided that a sub-committee does not have power to act other than by a resolution of the committee with specific limitations;
2. Does have the ability to make decisions in accordance with the Terms of Reference and the *Land Transport Management Act 2003*.

Power to Act (for the information of Council)

The Regional Transport Committee has the power to:

1. monitor any transport activities of the regional council, territorial authorities and New Zealand Transport Agency in order to report on progress on the Regional Land Transport Plan;
2. prepare and recommend variations to the Regional Land Transport Plan that trigger the RTC's significance policy;
3. consider and recommend transportation planning studies and associated outcomes;
4. provide recommendations to relevant government agencies on transport priorities for the region and the allocation of national or regional transport funds.

Council Established Working Groups

ECO Fund Decision Panel Chair

- Cr Michael Deaker

Port Otago Liaison Working Group

Purpose - to liaise with Port Otago Chair and Chief Executive and report to Council.

- Chair, Kevin Malcolm
- Council Chair, Cr Andrew Noone
- Finance Co-Chair, Cr Hilary Calvert
- Chief Executive

Catchment Catchment Community Governance Group

- Chair, Councillor Bryan Scott
- Cr Kate Wilson (alternate)

COVID-19 Recovery/Jobs for Nature Working Group

- Chair, Councillor Bryan Scott
- Cr Alexa Forbes
- Cr Gretchen Robertson
- Cr Kate Wilson

Appointments as Representatives of Council

Mana to Mana

Purpose – to manage the relationship between Otago Regional Council and Rūnanga in Otago.

- Council Chairperson – Cr Andrew Noone
- Council Deputy Chairperson – Cr Michael Laws
- Cr Michael Deaker
- Cr Alexa Forbes
- Cr Carmen Hope
- Cr Gretchen Robertson

Local Government New Zealand Regional Sector Group and Zone 6 Group

- Council Chairperson – Cr Andrew Noone
- Council Deputy Chairperson – Cr Michael Laws

Otago Mayoral Forum / CDEM Joint Committee

- Council Chair – Cr Andrew Noone
- Council Chief Executive

Manuherekia Reference Group

- Cr Andrew Noone
- Cr Kevin Malcolm

Connecting Dunedin

- Chair, Cr Andrew Noone
- Cr Alexa Forbes
- Cr Michael Deaker
- Cr Kate Wilson (nominated alternate)

Way to Go

- Chair, Cr Andrew Noone
- Cr Alexa Forbes
- Cr Kate Wilson

Lower Waitaki River Scheme Liaison

- Cr Kevin Malcolm

Dunedin Hospital Liaison and Tertiary Precinct Planning Group

- Cr Michael Deaker

Dunedin Tracks Network Trust (DnTNT)

- Cr Kate Wilson
- Cr Bryan Scott (alternate)

Freshwater Management Unit (FMU) and rohe Liaisons

The governance model adopted on 27 May 2020 for the development of the Land and Water Regional Plan includes two councillors permanently on the LWRP Governance Group (Councillor Andrew Noone and Councillor Gretchen Robertson), and two rotating councillors as nominated Freshwater Management Unit liaisons. The nominated FMU liaisons are below. These councillors will slot into the agreed process, as and when the rohe come up for review.

Upper Lakes Rohe	Cr Gary Kelliher
Dunstan	Crs Alexa Forbes and Michael Laws
Manuherekia	Crs Andrew Noone and Kevin Malcolm
Lower Clutha	Cr Gretchen Robertson
Taieri	Cr Carmen Hope
Dunedin Coast	Crs Bryan Scott and Hilary Calvert
North Otago	Cr Kevin Malcolm
Catlins	Cr Kate Wilson
Roxburgh	Crs Alexa Forbes and Michael Laws
Clutha (main stem)	Cr Michael Deaker
Arrow and Cardrona	Cr Bryan Scott

Freshwater Management Unit (FMU) Map

