



Committee Structure, Membership and Terms of Reference

2022 - 2025 Triennium

Adopted: 7 December 2022

Table of Contents

Otago Regional Council Committee Memberships 3

Regional Leadership Committee 4

Finance Committee..... 5

Audit and Risk Subcommittee 6

Environmental Science and Policy Committee 7

Environmental Implementation Committee 8

Safety and Resilience Committee 9

Public and Active Transport Committee..... 10

Otago Civil Defence Emergency Management Group (Joint Committee) 11

Otago Regional Transport Committee..... 14

Council Established Working Groups 18

Appointments as Representatives of Council 20

Land and Water Regional Plan: Freshwater Management Unit (FMU) and Rohe Liaisons 21

Otago Regional Council Committee Memberships

| Finance Committee | Environmental Science and Policy Committee | Environmental Implementation Committee |
|---|---|---|
| Co-Chairs: Kevin Malcolm, Tim Mepham | Co-Chairs: Lloyd McCall, Iwi Representative | Co-Chairs: Bryan Scott, Kate Wilson |
| Committee of the Whole | Committee of the Whole Iwi representatives (2) | Committee of the Whole |

| Public and Active Transport Committee | Regional Leadership Committee | Safety and Resilience Committee |
|--|--|--|
| Co-Chairs: Alexa Forbes, Andrew Noone | Co-Chairs: Bryan Scott, Elliot Weir, Michael Laws | Co-Chairs: Gary Kelliher, Alan Somerville |
| Committee of the Whole | Committee of the Whole Iwi representative (1) | Committee of the Whole |

| Audit and Risk Subcommittee | Civil Defence and Emergency Management Joint Committee | Regional Transport Committee <i>(established by the Land Transport Management Act)</i> |
|---|---|---|
| Co-Chairs: Tim Mepham, Independent Member Alexa Forbes Gary Kelliher Kevin Malcolm Gretchen Robertson Kate Wilson | ORC Chair Otago Mayors | Kate Wilson (ORC), Chair Alexa Forbes (ORC), Deputy Ch Cr Jim O'Malley (DCC) Cr Bruce Graham (CDC) Cr Stuart Duncan (CODC) Cr Quentin Smith (QLDC) Cr Jim Thomson (WDC) Mr James Caygill (NZTA) Alternates: Cr Kevin Gilbert (DCC) Cr (NZTA) Cr Guy Percival (WDC) |

Regional Leadership Committee

| | |
|--------------------------|---|
| Co-Chairs | Bryan Scott, Elliot Weir, Michael Laws |
| Members | All councillors Iwi Representative (1) |
| Quorum | Seven (7) |
| Meeting frequency | Quarterly |

Purpose: To provide recommendations and advice to Council on Regional Leadership activities of the ORC Long-term Plan 2021-31. Monitor governance, communications, and regulatory functions of Council. Champion the Council’s partnership with Kāi Tahu and engagement with Māori and uphold the four “wellbeings” in the work of Council.

Areas of responsibility

- Develop, and monitor implementation of Council’s Strategic Directions
- Be the guardians of the Council’s partnership with Kāi Tahu, engagement with Māori, and upholding the Treaty of Waitangi in the work of Council
- Develop and review Council positions and submissions, and advocacy on behalf of the Otago region on national and regional plans, policies and legislation
- Consider and develop community engagement plans, including how to reach new/all communities
- Monitor implementation of ORC’s Regional Policy Statement
- Provide oversight of ORC’s climate change mitigation responses and regional strategies and plans
- Participate in joint urban development policy development and consideration alongside Territorial Authorities, and other obligations set out by the National Policy Statement Urban Development
- Provide regional leadership in urban development policy direction, including by engaging with Territorial Authorities and by taking a regional approach to urban growth and development
- Consider Council meeting schedules, remuneration, and governance matters.
- As needed consider communications strategies (*noting that communications plans will be considered by the relevant committee alongside the work area*)
- Receive and review quarterly reporting from the Regulatory Group (including Harbourmaster, but excluding Biosecurity Act reporting)
- Consider and make recommendations to Council on a wellbeing framework as required under the Long-term Plan.

Delegations

The Committee has no general decision-making or financial delegations. It can:

1. Receive information for noting.
2. Make recommendations to Council on the matters within its responsibility.
3. Appoint working parties as appropriate provided they are limited to a time duration consistent with performance of their specified tasks and receive reporting from them.
4. Carry out any other function or duty delegated to it by the Council.

Finance Committee

| | |
|--------------------------|---------------------------|
| Co-Chairs | Kevin Malcolm, Tim Mepham |
| Members | All Councillors |
| Quorum | Six (6) |
| Meeting frequency | Quarterly |

Purpose: To guide, monitor and provide advice to Council on the Council's financial, commercial, and administrative affairs, including the Port shareholding and operational performance, Long-term Plan, Annual Plans, and implementation of the Local Government Act 2002.

Areas of Responsibility

- Review and monitor quarterly activity reporting against the agreed levels of service and target measures outlined in the Long-term and Annual Plans
- Review and monitor quarterly and annual financial statements including the statement of comprehensive income, balance sheet and treasury report
- Lead Long-term and Annual Plan process including consultation and hearings and make recommendations to Council for adoption
- Oversee and make recommendations to Council on financial policies including the Financial Strategy and Revenue and Financing Policy
- Oversee and make recommendations to Council on Rates, fees, charges, royalties and rentals policies and strategies
- Manage affairs with Port Otago Ltd (including Statement of Corporate Intent and receive the six month and annual reports)
- Review and monitor commercial activities, trading activities or investments held by the Council
- Review and monitor Council's assets, leases, and financial reserves

Delegations

- Receive information for noting.
- To award or approve contracts and tenders in excess of staff delegations and to a maximum of \$2million.
- To consider and make recommendations to Council matters of financial impact other than as provided for in the Annual Plan.
- The Finance Committee shall carry out any other function or duty delegated to it by the Council.
- The Finance Committee may appoint subcommittees or working parties as appropriate provided they are limited to a time duration consistent with performance of their specified tasks.

Audit and Risk Subcommittee

| | |
|--------------------------|--|
| Co-Chairs | Tim Mepham, Independent Member TBA |
| Members | Alexa Forbes Gary Kelliher Kevin Malcolm Gretchen Robertson (Ex Officio member) Kate Wilson Other councillors are encouraged to attend meetings of the Subcommittee, but do not have voting rights. |
| Quorum | Four (4) |
| Meeting frequency | Quarterly |

Purpose: To provide advice about governance, risk management, and internal control matters, external reporting and audit matters. The Subcommittee can make recommendations to the Council and/or the chief executive, and request information and advice through the chief executive when necessary.

Areas of Responsibility

- Council's risks and management of those risks,
- Strategic risk register and management of risks on the register
- Insurance renewals and notifications
- Annual audit process, including audit plan, management letter, and management response, and reviewing the draft annual report before it goes to Council
- Internal audit and control process
- Health and Safety reporting
- Investment management, including managed fund, performance of Council's investment manager including compliance of the managed fund with the Statement of Investment Policies and Objectives (SIPO), and appointment of fund manager.
- Legal compliance
- The Co-Chairs will report to Council annually on the activities of the Subcommittee.

Delegations

The Subcommittee has no general decision-making or financial delegations. It can:

- Receive information for noting.
- Receive the external audit engagement letters and letters of undertaking for audit functions and additional services provided by the external auditor.
- Review matters within its areas of responsibility and make recommendations to Council on those matters.
- Seek information it requires from the Chief Executive. The Chief Executive is required to cooperate with any requests unless excused by the Chair of the Otago Regional Council.
- Request access to outside legal or independent professional advice should it consider this necessary.

Environmental Science and Policy Committee

| | |
|--------------------------|--|
| Co-Chairs | Lloyd McCall, Iwi Representative |
| Members | All Councillors Iwi representatives (2) |
| Quorum | Seven (7) |
| Meeting frequency | As needed |

Purpose To provide advice and guidance to Council on the development of Otago’s environmental (water, land, air, biodiversity and biosecurity) plans, policies and strategies under the Resource Management Act, Biosecurity Act and other national directions. To ensure, through appropriate science and performance monitoring, the effective promotion of sustainable management of natural and physical resources of the Region. To ensure the Council partnership with Kāi Tahu is reflected in the above processes.

Areas of Responsibility

- Land and Water Regional Plan development, including policy, science, economics inputs
- Coast plan review, including the policy and science inputs
- Air Plan review, including the policy and science inputs
- Regional Pest Management Plan, including the policy and science inputs
- Creation of Biodiversity plans, including the policy and science inputs
- Strategy development related to the environment (water, air, land, coast, biodiversity and biosecurity)
- Receive and review science inputs as part of the policy, strategy and plan making process
- Review of State of the Environment monitoring, analysis and reporting

Delegations

The Committee has no general decision-making or financial delegations. It can:

1. Receive information for noting.
2. Receive reporting from the Land and Water Regional Plan Governance Group.
3. Make recommendations to Council on the matters within its responsibility.
4. Appoint working parties as appropriate provided they are limited to a time duration consistent with performance of their specified tasks.
5. Carry out any other function or duty delegated to it by the Council.

Environmental Implementation Committee

| | |
|--------------------------|--------------------------|
| Co-Chairs | Bryan Scott, Kate Wilson |
| Members | All Councillors |
| Quorum | Six (6) |
| Meeting frequency | Quarterly |

Purpose To monitor and provide advice to Council on ORC’s delivery of environmental outcomes, and how we work with the community to achieve these environmental outcomes as set out in the Long-term Plan 2021-31 under the Environment activity (namely water, land, air, biodiversity and biosecurity).

Areas of Responsibility

- Monitor implementation of activities related to (but not limited to):
 - ORC work with catchment groups and Otago Catchment Community
 - Biodiversity strategy implementation
 - Biosecurity strategy/operational plan implementation
 - Air Strategy implementation
- Development and implementation of the Integrated Catchment Management programme
- Development of annual Biosecurity Operational Plan.
- Oversee the ECO Fund
- Receive biosecurity outcomes/compliance reporting

Delegations

The Committee has no general decision-making or financial delegations. It can:

1. Receive information for noting.
2. Make recommendations to Council when decisions are needed.
3. Appoint working parties as appropriate provided they are limited to a time duration consistent with performance of their specified tasks.
4. Carry out any other function or duty delegated to it by the Council.

Safety and Resilience Committee

| | |
|--------------------------|--------------------------------|
| Co-Chairs | Gary Kelliher, Alan Somerville |
| Members | All Councillors |
| Quorum | Six (6) |
| Meeting frequency | Quarterly |

Purpose To consider and set the direction for programmes of work and provide advice to Council on matters that fall under the Safety and Resilience activity of the ORC's Long-term Plan 2021-31.

Areas of Responsibility

- Review and advise Council on ORC's programme of work on climate change adaptation
- Oversee the Otago Climate Change Risk Assessment
- Monitoring natural hazards risks and programmes to manage those risks
- Oversee and monitor waterway management, flood control and land drainage
- Oversee and monitor the condition and performance of council's river management, flood control and land drainage schemes and service delivery risks
- Natural hazards monitoring and warning systems and processes
- Monitor delivery of ORC's Civil Defence and Emergency Management responsibilities

Delegations

The Committee has no general decision-making or financial delegations. It can:

1. Receive information for noting.
2. Make recommendations to Council when decisions are needed.
3. Appoint working parties as appropriate provided they are limited to a time duration consistent with performance of their specified tasks.
4. Carry out any other function or duty delegated to it by the Council.

Public and Active Transport Committee

| | |
|--------------------------|----------------------------|
| Co-Chairs | Andrew Noone, Alexa Forbes |
| Members | All Councillors |
| Quorum | Six (6) |
| Meeting frequency | Quarterly (or as needed) |

Purpose To set the strategic and operational direction for approved Regional Council public transport policy and strategy, and monitor its implementation.

Areas of Responsibility

- Prepare and review the Otago Regional Public Transport Plan.
- Implement, monitor and review operational public transport policy and plans.
- Advocate for public transport with Waka Kotahi NZTA, territorial authorities, and Central Government.
- Set and monitor targets for public transport in the region.
- Oversee Public Transport Dunedin provision of service, routes, data, contracts, complaints, and communications
- Oversee Public Transport Queenstown provision of service, routes, data, contracts, complaints, and communications
- Regional Total Mobility Service
- In coordination with the work programme of the Regional Transport Committee, guide and review the public transport components of the Regional Land Transport Plan (RLTP) and make recommendations to Regional Transport Committee for incorporation into the RLTP.
- Receive reporting from the Regional Transport Committee
- Receive reporting from any working groups set up under this Committee

Delegations

The Committee has no general decision-making or financial delegations. It can:

1. Receive information for noting.
2. Make recommendations to Council when decisions are needed.
3. Appoint working groups with representatives from territorial authorities and other agencies as appropriate provided they are limited to a time duration consistent with performance of their specified tasks and receive reporting from those working groups.
4. Carry out any other function or duty delegated to it by the Council.

Otago Civil Defence Emergency Management Group (Joint Committee)

| | |
|--------------------------|--|
| Chairperson | To be confirmed |
| Members | <ul style="list-style-type: none">• Central Otago District Council• Clutha District Council• Dunedin City Council• Otago Regional Council• Queenstown Lakes District Council• Waitaki District Council <p>Each member is represented on the joint committee by the Mayor/ Chairperson, or by an elected person from that authority who has delegated authority to act for the member.</p> |
| Quorum | Three (3) |
| Meeting frequency | Quarterly |

Constitution

Pursuant to section 12 of the Civil Defence Emergency Management Act 2002, the Otago Civil Defence Emergency Management Group is constituted as a joint standing committee under section 114S of the Local Government Act 1974 (a joint committee under section 30 of Schedule 7 of the Local Government Act 2002) by resolutions adopted by:

- Central Otago District Council
- Clutha District Council
- Dunedin City Council
- Otago Regional Council
- Queenstown Lakes District Council
- Waitaki District Council

Chairperson

The Otago Civil Defence Emergency Management Group shall appoint one of the representatives of its members as chairperson, and one of its members as deputy chairperson. Each will hold office for such period as agreed by the Group, but only so long as those persons remain a representative of a member of the Group.

Purpose

The Otago Civil Defence Emergency Management Group has the purpose and all of the functions, powers and obligations of a civil defence emergency management group as defined by the Civil Defence Emergency Management Act 2002 and subsequent amendments. Section 17 of the Civil Defence Emergency Management Act 2002 defines the function of a group and each of its members that, in summary, require it to:

- Identify, assess and manage relevant hazards and risks;

- Ensure provision of trained and competent personnel, an appropriate organisational structure and the necessary services and resources for effective civil defence emergency management in its area;
- Respond to and manage the adverse effects of emergencies;
- Carry out recovery activities;
- Assist other civil defence emergency management groups when requested;
- Promote public awareness of and compliance with the Civil Defence Emergency Management Act and legislative provisions relevant to the purpose of the Act;
- Develop, approve, implement, monitor and review a civil defence emergency management group plan;
- Participate in the development of the national civil defence emergency management strategy and the national civil defence emergency management plan.
- Promote civil defence emergency management in its area that is consistent with the purpose of the Civil Defence Emergency Management Act 2002.

Delegations

The Otago Civil Defence Emergency Management Group shall have all the delegated authorities that may be given by each member Council, including authority to fulfil the powers, obligations and functions of the Group as specified in the Civil Defence Emergency Management Act 2002, authority to appoint subcommittees, and authority to sub-delegate any authority able by law to be delegated.

Subcommittee

A subcommittee of all members of the Otago Civil Defence Emergency Management Group may be formed and given full delegated authority to carry out the functions, obligations and powers of the Group under the Civil Defence Emergency Management Act 2002 pursuant to section 114P(2) of the Local Government Act 1974 and section 30(2) schedule 7 of the Local Government Act 2002. Any meeting will transact routine business and not commit members to any major financial expenditure.

Standing Orders

The current Standing Orders of the Otago Regional Council shall govern the conduct of the meetings, except that order papers and agenda papers shall be sent to every member no less than five working days before the meeting. Notwithstanding anything in the Civil Defence Emergency Management Act or Standing Orders, adequate notice shall be given of all matters to be discussed at a meeting of the Group. Where a matter of significance is to be considered, where practicable, prior written notice of the background to that matter must be given in sufficient time to allow for consultation with each member.

Administering Authority

The Otago Regional Council as the administering authority shall provide administrative and leadership of the Group.

Reporting

The Group will report to each member.

Continuance of Joint Standing Committee

The Otago Civil Defence Emergency Management Group shall not be discharged by a triennial election but appointments of representatives of members shall be confirmed or new appointments made by each council following each election.

Otago CDEM Group Governance Structure

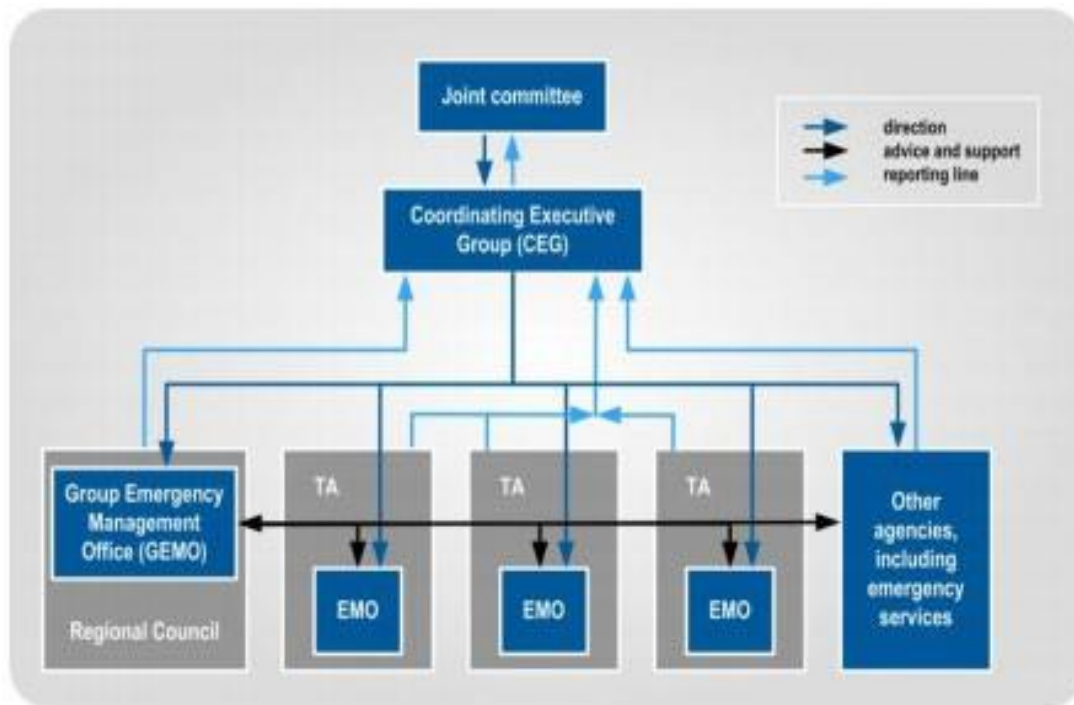

The **Otago CDEM Group Joint Committee**, made up of all the mayors from the five districts and the chairperson of the Regional Council, has overall governance responsibility for CDEM in the Otago area.

Operational management is supported by the **Coordinating Executive Group (CEG)**, made up of the Chief Executives of the six councils (or persons acting on their behalf), plus senior representatives from the NZ Police, Fire and Emergency NZ, St John, Southern District Health Board, Ngāi Tahu and the Ministry of Social Development. The CEG provides advice to the JC and ensures its decisions are implemented.

Otago CDEM Group Management Office is a shared service across all six local authorities of Otago. Otago Regional Council is the Administering Authority for the CDEM Group. It:

- Employs all staff of Otago CDEM Group and is responsible for all employment-related matters including health and safety, wellbeing, welfare, operational policies, and conduct.
- Provides administrative and related services to the Group, such as preparing agendas, arranging meetings, and taking and disseminating minutes from meetings.
- Provides financial management for the CDEM Group, including budgeting and reporting.

In addition to the funding collected by the Regional Council through the targeted rate to resource the Otago CDEM Group and its activities.

Each **local authority member** of the Group is operationally and financially responsible for its **own local arrangements**. Each council also contributes skills, expertise and mutual support to the Group on an 'as available' basis.

For more information please see: <https://www.otagocdem.govt.nz/media/1417/otago-cdem-group-plan-2018-28-print-version.pdf>

Otago Regional Transport Committee

| | |
|---|---|
| Chairperson | Alexa Forbes, Otago Regional Council |
| Deputy Chairperson | Kate Wilson, Otago Regional Council |
| <p>Members</p> <p>Total membership of the Otago committee equals eight. This is dictated by Section 105 of the Land Transport Management Act 2003 (LTMA).</p> <p>Representatives are appointed by the Regional Council on the nomination of NZ Transport Agency and each of the territorial local authorities.</p> | <p>Two regional council representatives (Chair and Deputy Chair);</p> <p>One representative from the Waka Kotahi NZ Transport Agency</p> <p>One district council representative from each of the:</p> <ul style="list-style-type: none"> • Central Otago District Council • Clutha District Council • Dunedin City Council • Queenstown Lakes District Council • Waitaki District Council <p>Alternates:</p> <ul style="list-style-type: none"> • Central Otago District Council • Clutha District Council • Dunedin City Council • Queenstown Lakes District Council • Waitaki District Council |
| Quorum / Voting | <p>An Otago RTC meeting cannot proceed unless five committee members are present, at least one of whom must be representative of the regional council and no more than one to be an alternate representative.</p> <p>No voting will occur unless there is a quorum of committee members from those organisations allowed to vote on these matters.</p> <p>The Chairperson has a deliberative vote and in the case of an equality of votes does not have a casting vote. Clause 24 of the 7th Schedule of the Local Government Act otherwise applies to voting.</p> <p>The purpose of encouraging each organisation to have alternates is to ensure that each of the organisations involved in the RTC (the TAs, Waka Kotahi NZ Transport Agency and the regional council) is able to bring their organisation's view to the table</p> |

| | |
|---------------------------------|---|
| | <p>and to report back the outcome to their organisation.</p> <p>Each organisation (i.e., the regional council, Waka Kotahi NZ Transport Agency and each district/city council) is therefore encouraged to have alternative representatives to act as a replacement should the appointed representative be absent from a meeting.</p> <p>Alternates will count towards a quorum but do not have voting rights.</p> |
| <p>Meeting frequency</p> | <p>The RTC normally meets at least three times a year but may meet more regularly depending on the work to be undertaken or the issues to be addressed. Where possible, members will be advised, in advance, of the meeting schedule for the year.</p> <p>Typically, the Otago RTC meets alongside the Southland RTC.</p> |

Purpose

To undertake the functions as prescribed by the *Land Transport Management Act 2003 and subsequent amendments*.

Role and Functions

The role and functions of the Regional Transport Committee are as follows:

1. To undertake the statutory requirements of the *Land Transport Management Act 2003*;
2. To prepare the Regional Land Transport Plan (RLTP) in co-operation with the Otago Regional Transport Committee, to prepare any applications to vary the RLTP and to process any applications to vary the RLTP (*LTMA Section 106(1)(a)*);
3. To prepare and adopt a policy that determines significance in respect of:
 - a) any variations made to the RLTP;
 - b) activities included in the RLTP (*LTMA Section 106(2)*).
4. To provide any advice and assistance the regional council may request on its transport responsibilities generally (*LTMA Section 106(1)(b)*);
5. To undertake monitoring to assess implementation of the Regional Land Transport Plan including monitoring of the performance of activities (*LTMA Section 16(3)(f) and 16(6)(e)*), in co-operation with the Otago Regional Transport Committee;

6. To consult on a draft RLTP for the region in accordance with the consultation principles specified in Section 18 and 18A of the *Land Transport Management Act 2003*, in co-operation with the Otago Regional Transport Committee;
7. To complete a review of the RLTP during the six-month period immediately before the expiry of the third year of the Plan (*LTMA Section 18CA*) in co-operation with the Otago Regional Transport Committee;
8. To advise the Council on any significant legislative changes, programmes, plans or reports relating to the region's transport system;
9. To prepare and implement regional transportation planning studies, or pan-regional studies with the Otago Regional Transport Committee, when necessary;
10. To represent and advocate for transport interests of regional and/or pan-regional Otago Southland concern;
11. To consider and submit on transport-related policies, plans and consultation documents issued by the Ministry of Transport, Waka Kotahi NZ Transport Agency, regional/district councils, and other relevant organisations as considered appropriate, including submitting jointly with the Otago Regional Transport Committee, when appropriate;
12. To liaise with the Ministry of Transport, Waka Kotahi NZ Transport Agency, Commissioner of Police, regional/district councils, KiwiRail, the Department of Conservation and other interested parties on transport matters, and advise the Council on any appropriate new initiatives as considered appropriate;
13. To operate in a collaborate manner in the combined meetings of the Otago and Southland regional transport committees and to engage with other regional transport committees and working parties, which from time-to-time may be established;
14. To consider advice and recommendations from the Otago Southland Regional Technical Advisory Group.

Members' responsibilities for reporting back to the organisation they represent

Each member of the Regional Transport Committee is expected to report back to their own organisations following each Regional Transport Committee meeting or workshop on matters discussed at those Committee meetings, and with particular reference to the RLTP. A briefing paper will be produced by the Regional Council for distribution to stakeholders and to assist members with their report back responsibilities.

Terms of Membership

Should a vacancy occur in the membership of the RTC, the Committee Secretary shall report this to the next meeting of the Council, which shall then invite the nominating organisation to nominate a replacement.

Delegated Authority – Power to Act

The Regional Transport Committee:

1. Does have the ability to appoint a panel to hear RLTP, submissions, working parties, advisory groups and, where there is urgency or special circumstances, a sub-committee to deal with any

matters of responsibility within the Committee's Terms of Reference and areas of responsibility, and to make recommendations to the Committee on such matters, provided that a sub-committee does not have power to act other than by a resolution of the committee with specific limitations;

2. Does have the ability to make decisions in accordance with the Terms of Reference and the *Land Transport Management Act 2003*.

Power to Act (for the information of Council)

The Regional Transport Committee has the power to:

1. Monitor any transport activities of the regional council, territorial authorities and New Zealand Transport Agency in order to report on progress on the Regional Land Transport Plan;
2. Prepare and recommend variations to the Regional Land Transport Plan that trigger the RTC's significance policy;
3. Consider and recommend transportation planning studies and associated outcomes;
4. Provide recommendations to relevant government agencies on transport priorities for the region and the allocation of national or regional transport funds.

Council Established Working Groups

Meetings to be as required

ORC Chairperson is Ex Officio member of all working groups

| | |
|--|--|
| <p>Port Otago Liaison Working Group</p> <p><i>Established by Council, 2016</i></p> <p><i>Reports to Council</i></p> | <p>Chair, Cr Kevin Malcolm Council Chair – Cr Gretchen Robertson Finance Co- Chair – Cr Tim Mephram Council Deputy Chair - Cr Lloyd McCall CE</p> |
| <p>ECO Fund Decision Panel Chair</p> <p><i>Established by Council in 2019</i></p> <p><i>Reports to Environmental Implementation Committee and Council</i></p> | <p>Cr Alan Somerville</p> |
| <p>Land and Water Regional Plan Governance Group</p> <p><i>Established by Council, May 2020</i></p> <p><i>Reports to Environmental Science and Policy Committee</i></p> | <p>Council Chair - Cr Gretchen Robertson Cr Andrew Noone</p> |
| <p>ORC Whare Rūnaka Internal Steering Group</p> <p><i>Established by Council, October 2021</i></p> <p><i>Reports to Council</i></p> | <p>Council Chair – Gretchen Robertson Cr Kevin Malcolm Cr Andrew Noone</p> |
| <p>Otago Integrated Catchment Management (ICM) Working Group</p> <p><i>Established by Council, September 2022</i></p> <p><i>Reports to Environmental Implementation Committee</i></p> | <p>Chair: Cr Lloyd McCall Deputy Chair: Cr Kate Wilson (FMU Catlins Councillor)</p> |
| <p>Submissions Working Group</p> <p><i>Established by Council, December 2022 (to be confirmed)</i></p> <p><i>Purpose:</i></p> <ul style="list-style-type: none"> • To receive draft submissions and provide input and review feedback, ahead of submissions going to Council for approval, to help with timeliness and direction. • To seek support from councillors for submission positions ahead of them going to council for approval. <p><i>Reports to Regional Leadership Committee</i></p> | <p>Members:</p> <ul style="list-style-type: none"> • Cr Lloyd McCall (Chair) • Cr Andrew Noone • Cr Kate Wilson • Cr Elliot Weir |

| | |
|--|---|
| <p>Resource Management Reform Working Group</p> <p><i>Established by Council, December 2022 (to be confirmed)</i></p> <p><i>Purpose:</i></p> <ul style="list-style-type: none">• Monitor and review resource management reform and its impacts on the ORC• Provide updates to Council about developments• Provide inputs to submissions on the reforms <p><i>Reports to Regional Leadership Committee</i></p> | <p>Members:</p> <ul style="list-style-type: none">• Cr Andrew Noone (Chair)• Cr Kate Wilson• Cr Lloyd McCall• Cr Elliot Weir |
|--|---|

Appointments as Representatives of Council

| | |
|---|--|
| Mana to Mana | All councillors |
| Te Rōpū Taiao Southland | Chair – Cr Gretchen Robertson Deputy Chair – Cr Lloyd McCall |
| LGNZ Zone 6 | Chair – Cr Gretchen Robertson Deputy Chair – Cr Lloyd McCall Attendance shared between Councillors |
| Regional Sector Group (RSG) | Chair/CE |
| Mayoral Forum | Chair/CE |
| CDEM Joint Committee | Chair/CE |
| Connecting Dunedin (transport related) | Cr Andrew Noone Cr Kate Wilson Cr Elliot Weir |
| Way to Go (Whakatipu) (transport related) | Cr Andrew Noone Cr Alexa Forbes Cr Kate Wilson |
| Dunedin Tracks Network Trust (DnTNT) | Cr Kate Wilson Cr Bryan Scott (alternate) |
| Dunedin Hospital Liaison Group | Cr Gretchen Robertson |
| Tertiary Precinct Planning Group | Cr Elliot Weir |
| Lower Waitaki River Scheme Liaison | Cr Kevin Malcolm |
| Otago Catchment Community (OCC) Governance Group | Cr Bryan Scott Cr Kate Wilson (alternate) |
| Manuherehia Exemplar Catchment Programme Governance Group (MfE) | Cr Kevin Malcolm Cr Michael Laws and Cr Lloyd McCall (alternate) CE |
| Regional Co-ordination Group for Wilding Conifer Management | Cr Alexa Forbes Cr Kate Wilson (alternate) |
| Regional Co-ordination Group for Wallaby Management | Cr Kevin Malcolm Cr Gary Kelliher (alternate) |
| Otago South River Care Group Governance Group | Cr Kate Wilson Cr Tim Mephram (alternate) |
| Grow Well Whaiora Partnership Governance Group (Queenstown Future Development Strategy Group) | Cr Andrew Noone Cr Alexa Forbes |
| *note a separate paper will come on the DCC Future Development Strategy Group, as the governance arrangements for this are still to be considered | |

Land and Water Regional Plan: Freshwater Management Unit (FMU) and Rohe Liaisons

| | |
|----------------------------|---|
| Upper Lakes Rohe | Crs Michael Laws, Alexa Forbes |
| Dunstan | Crs Alexa Forbes, Michael Laws |
| Manuherekia | Crs Kevin Malcolm, Tim Mephram |
| Lower Clutha | Crs Andrew Noone, Alan Somerville |
| Taieri | Crs Gretchen Robertson, Lloyd McCall |
| Dunedin and Coast | Crs Bryan Scott, Elliot Weir |
| North Otago | Crs Kevin Malcolm, Elliot Weir |
| Catlins | Crs Kate Wilson, Lloyd McCall |
| Roxburgh | Cr Gary Kelliher (Kate Wilson, alternate) |
| Clutha Mata-Au (Main Stem) | Cr Kate Wilson (Bryan Scott, alternate) |
| Arrow and Cardrona | Crs Bryan Scott, Gary Kelliher |

